

Troubleshooting Op-Amps

The op-amp is a widely used integrated circuit (IC) used to construct circuits that range from simple level detectors to complex multi-pole filters. The student/technician may feel overwhelmed when faced with the task of troubleshooting op-amp circuits because of their complexity. Too often the student or technician will simply assume that the op-amp is “bad” when the circuit’s response is incorrect. This leads to the unnecessary replacement of components, damage to printed circuit boards, and wasted time and lost production.

Troubleshooting op-amp circuits will be made simpler by having a firm foundation in the operation of basic op-amp circuits and through knowing a few simple troubleshooting techniques. The following discussion is based on the 741 op-amp. This is one of the most widely used, general-purpose op-amps in the electronics industry. However, the student should understand that many devices are represented with schematic symbols that look like op-amps, but operate differently.

Refer to Figure 1. The op-amp must be connected to a DC voltage source in order to operate. The DC power connection points are labeled $+V_{CC}$ and $-V_{EE}$. The voltages applied to $+V_{CC}$ and $-V_{EE}$ can be as large as $\pm 22V$. There are two input terminals to the op-amp. They are the non-inverting input (+) and the inverting input (-). The op-amp has a single output terminal. The output is labeled V_{out} . The op-amp is a voltage amplifier. This means that the op-amp has high input impedance, low output impedance, and a high voltage gain, and that the output can only supply limited amounts of current.

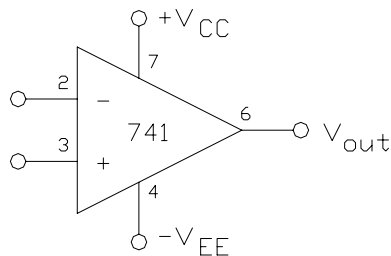

Figure 1

Understanding and memorizing the following six approximations regarding op-amps will make circuit analysis and troubleshooting easier.

1. The output impedance (Z_{out}) of an op-amp is zero (0Ω).
2. The input impedance (Z_{in}) of an op-amp is infinite ($\infty\Omega$).
3. The voltage gain (A_V) is infinite.
4. The maximum output current (I_{out}) is 25mA.
5. The output voltage (V_{out}) is always between $+V_{CC}$ and $-V_{EE}$.
6. When a negative feedback path exists, the output will make the inverting and non-inverting inputs at the same potential.

Op-amp circuits can be grouped into three general categories based on the type of feedback used in the circuit. A feedback path is a connection, or path for current, from the output of the op-amp back to one of the input terminals. The first step in analyzing or troubleshooting an op-amp circuit is recognizing which, if any, feedback path exists and understanding how each type of feedback affects the op-amp's operation.

1. Negative feedback: The output sends a voltage back to the input such that it opposes the original change in the output. This is probably the most commonly used type of feedback. The op-amp is said to be operating in the linear mode when a negative feedback is employed. In the linear mode, the voltage gain of the op-amp circuit is controlled through the values of the feedback elements.
2. Positive feedback: The output sends a voltage back to the input such that it reinforces the original change in the output. The output will always be saturated when positive feedback is used. This means that the output will either be at its positive or negative limits. The positive limit of the output is approximately $+V_{CC}-2V$ and the negative limit of the output is approximately $-V_{EE}+2V$. These are often referred to as the rail voltages.
3. No feedback: The output is not connected back to either input terminal. The output of the op-amp will always be saturated when there is no feedback path present.

It is difficult to effectively and efficiently troubleshoot an electronic circuit without possessing a basic understanding of the circuit's operation. Before discussing any op-amp troubleshooting theory and techniques, the operation of two commonly used op-amp circuits will be discussed.

Inverting Voltage Amplifiers

One of the most widely used op-amp configurations is the inverting voltage amplifier. The basic inverting voltage amplifier is shown in Figure 2. Even with no prior experience with op-amps, this circuit can be analyzed with knowledge of Ohm's law, Kirchhoff's voltage and current laws, and the six approximations listed on page 1.

Referring to the circuit of Figure 2, note that the source voltage, V_{in} , is applied to the inverting input through the resistor R_1 . Note, also, that the output is "fed back" to the inverting input through resistor R_2 . This satisfies the definition of negative feedback.

Approximation 6 states that when a negative feedback path exists the two input terminals will be at the same potential. Since the non-inverting input is tied directly to ground, the inverting input will also be at ground potential. The node that connects R_1 , R_2 , and the inverting input is called "virtual ground".

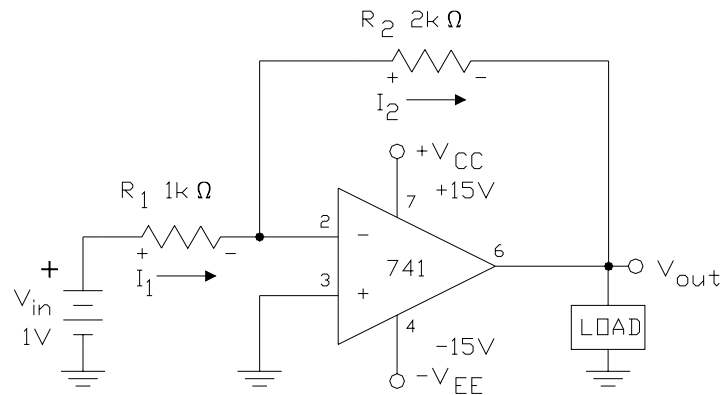

Figure 2

$V_{in}=1V$ in the circuit of Figure 2. Since the inverting input is virtual ground (0V), 1V is dropped across resistor R_1 ; the current flowing through R_1 , I_1 , equals 1mA. Approximation 2 states that the input impedance of the input terminals is infinite. Therefore, all of the 1mA that flows through R_1 must also flow through resistor R_2 .

If 1mA of current flows through resistor R_2 , the voltage dropped across resistor R_2 is 2V. Since the inverting input terminal (the left end of resistor R_2) is at virtual ground, the output of the op-amp will be $-2V$.

The steps taken to analyze the circuit of Figure 2 are as follows:

$$I_1 = \frac{V_{in}}{R_1}$$

$$I_2 = I_1$$

$$V_{R2} = (I_2)(R_2)$$

$$V_{out} = -V_{R2}$$

Non-Inverting Voltage Amplifiers

Another of the most widely used op-amp configurations is the non-inverting voltage amplifier. The basic non-inverting voltage amplifier is shown in Figure 3. As with the inverting voltage amplifier, this circuit can be analyzed with knowledge of Ohm's law, Kirchoff's voltage and current laws, and the six approximations listed on page 1.

Referring to the circuit of Figure 3, note that the source voltage, V_{in} , is applied directly to the non-inverting input. Note, also, that the output is “fed back” to the inverting input through resistor R_1 . This satisfies the definition of negative feedback. Approximation 6 states that the two input terminals will be at the same potential when a negative feedback path exists.

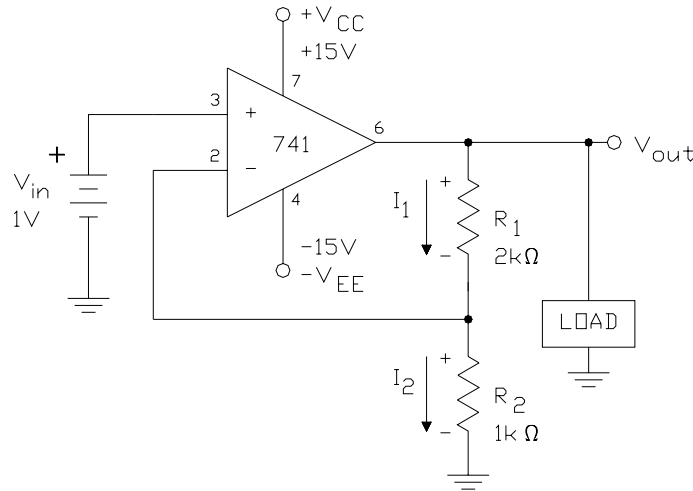

Figure 3

In the circuit of Figure 3, 1V is seen at the non-inverting input. Because a negative feedback path exists, the inverting input will also be 1V. Therefore, 1V must be dropped across resistor R_2 , and the current flowing through R_2 , I_2 , must equal 1mA.

Approximation 2 states that the input impedance of the input terminals is infinite. Consequently, all of the 1mA that flows through R_2 must also flow through resistor R_1 . With 1mA of current flowing through resistor R_1 , a potential difference of 2V will be developed across resistor R_1 . Since the node that connects the inverting input terminal, R_1 , and R_2 is +1V, the output of the op-amp will be +3V.

The steps taken to analyze the circuit of Figure 3 are as follows:

$$V_{R2} = V_{in}$$

$$I_2 = \frac{V_{R2}}{R_2}$$

$$I_1 = I_2$$

$$V_{R1} = (I_1)(R_1)$$

$$V_{out} = V_{R1} + V_{R2}$$

The preceding discussion provides a simple approach to the analysis of two common op-amp circuits. Again, this approach requires that the student only use Ohm's law and Kirchhoff's voltage and current laws along with the six approximations for op-amps presented on page 1.

Successful troubleshooting does not require a precise circuit analysis. However, the student/technician must understand circuit operation well enough to determine when a circuit is not functioning properly. Most importantly, successful troubleshooting requires that an approximate value for the voltages present at key nodes of a normally functioning circuit be determined.

Troubleshooting Op-Amp Circuits

Refer to the circuit shown in Figure 2. In order to satisfy the conditions set by the input voltage and the feedback circuit, the output of the op-amp must be $-2V$. The output of an op-amp can be correct only if the following conditions are met.

1. The op-amp must have the proper supply voltages.
2. The op-amp must have valid current paths for the input voltage and feedback.
3. The output must be able to supply enough voltage and current.
4. The internal circuitry of the integrated circuit must be functioning properly.

Assume that the output of this op-amp is something other than $-2V$. What steps should be taken to determine the failure? It is not acceptable to merely replace the op-amp, although this is the first step taken by many students and technicians.

The first step should be to measure the voltage at $+V_{CC}$ and $-V_{EE}$. Measure the voltage directly at the pins of the IC. There could be an open wire, a break in a trace on the printed circuit board (PCB), or a failed solder connection. If the supply voltages are not correct, trace the circuitry back to the power supply and determine the problem.

The next step should be to verify the current paths for the input and the feedback path. An open wire, a break in a trace in the PCB, a failed solder connection, or solder short between two pins of the IC may exist. Any of these conditions will compromise the current path. Check the circuitry visually and with an ohmmeter.

The next step should be to measure the voltage at the inverting input. In this op-amp configuration the inverting input terminal is referred to as virtual ground, and it should measure $0V$. If this point is not $0V$, the op-amp could be defective, or the op-amp could be "loaded down". This means that the output is being forced to supply excessive amounts of current. Approximation 4 states that the maximum output current of an op-amp is $25mA$. If the current demand on the output is more than $25mA$, the op-amp cannot satisfy the input and feedback requirements.

At this point it must be determined whether there is an internal circuitry failure or if the output is loaded down. This can only be determined by isolating the output pin of the op-amp IC. The circuit of Figure 4 shows the circuit with the output isolated.

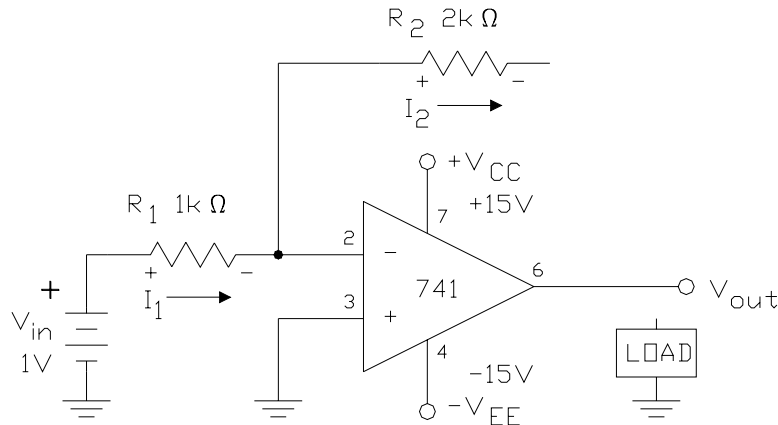

Figure 4

Desoldering the output pin of the IC package most easily isolates the output. However, care must be taken that no solder remains to connect the IC pin to the pad on the PCB. It may be preferable to desolder one end of the feedback resistor, R_2 , and one end of a component connected in series with the load.

With the output pin isolated, the output should go to the negative rail. This occurs because the feedback path is opened and a positive voltage is being applied to the inverting input. If the output is not at the negative rail, the op-amp is defective and must be replaced. If the op-amp is at the negative rail it cannot be assumed that the op-amp is functioning properly. The output could be stuck at the negative rail. A small negative voltage must be applied to the inverting input in order to force the output to the positive rail. Damage may occur to the IC if too large a voltage is applied to an input.

If there is no small negative voltage readily available on the PCB, one can be generated using a diode and a resistor. Figure 5 shows circuits that can be constructed to generate small positive and negative voltages.

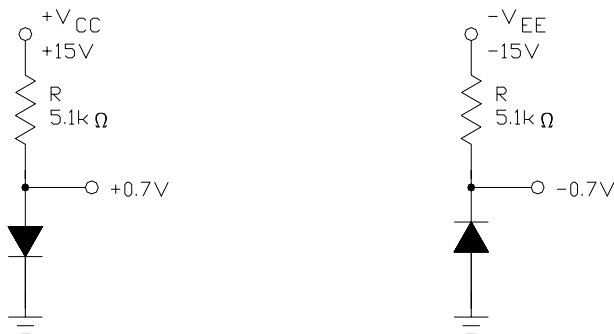

Figure 5

If applying a small negative voltage to the inverting input forces the output to the positive rail, the op-amp is probably functioning properly. If not, the op-amp is defective. If the output can be forced to the positive and negative rails the op-amp is most likely functioning properly, and the output is being loaded down.

In order to verify that the output is being loaded, it will be necessary to reconnect the feedback resistor, R_2 . With a feedback path and no load, the output should be the correct value of $-2V$. If the output is correct, the op-amp is functioning properly, but is excessively loaded. If the output is not $-2V$, the op-amp is defective.

The same method is used to troubleshoot a non-inverting voltage amplifier, such as the circuit shown in Figure 3. If the output is not correct, the output must be isolated so that the feedback path is opened and the load is removed. If the output cannot be forced to both the positive and negative rails, the op-amp is defective. If the output can be forced to both the positive and negative rails, the feedback path must be restored in order to determine if the output is being loaded down. If the output is not correct when the feedback path is restored and the load is still removed, the op-amp is defective. If the output is correct, there is some sort of failure in the load circuitry.